

LITERATURE CITED

1. Yu. L. Rastorguev, Yu. A. Ganiev, and G. A. Safronov, *Inzh.-Fiz. Zh.*, 33, No. 1 (1977).
2. H. Poltz, *Intern. J. Heat Mass Transfer*, 8, 609-620 (1965).
3. H. Poltz, *Intern. J. Heat Mass Transfer*, 10, 1075-1088 (1967).
4. H. Poltz, *Intern. J. Heat Mass Transfer*, 8, 815 (1965).
5. V. Z. Geller, I. A. Paramonov, and V. V. Slyusarev, *Inzh.-Fiz. Zh.*, 26, No. 6 (1974).
6. M. P. Vukalovich, S. L. Rivkin, and A. A. Aleksandrov, *Tables of the Thermal Properties of Water and Water Vapor [in Russian]*, Izd. Standartov, Moscow (1969).
7. H. Ziebland and J. T. A. Burton, *Intern. J. Heat Mass Transfer*, 1, 242 (1960).
8. B. C. Sakiadis and J. Coates, *Studies of the Thermal Conductivities of Liquids. Part 3. A Thermoconductimetric Apparatus for Liquids*, Baton Rouge (1954).

INVESTIGATION OF THE THERMODYNAMIC PROPERTIES OF
NITROGEN AT PRESSURES UP TO 8 kbar AND TEMPERATURES
UP TO 1800°K

A. A. Antanovich and M. A. Plotnikov

UDC 533.21

A procedure is described and the results are given of the experimental determination of the density of nitrogen at high pressures and temperatures.

For a number of the present-day domains of science and technology, information about the thermodynamic properties of industrially important gases at high pressures and temperatures is necessary. In particular, for the planning and operation of high-pressure aerodynamic facilities, intended for the generation of hypersonic gas flows with high Reynolds numbers, data are required concerning the thermodynamic properties of nitrogen at pressures of 5-20 kbar and temperatures up to 1000-3000°K.

However, the overwhelming majority of experimental papers on the determination of the thermodynamic properties of gases at high pressures is limited to temperatures of 600-700°K. This is due to the use of high-pressure equipment with external heating. The use of equipment with internal heating of the gas for thermophysical investigations was made difficult because of the intense gas convection arising in this equipment and disturbing the homogeneous nature of the temperature distribution inside the equipment [1].

The range of the parameters of state of nitrogen, investigated experimentally by different authors [2-5], is shown in Fig. 1.

Data which have appeared recently [5] at pressures up to 5 kbar and temperatures up to 1000°C are in need of verification. They disagree with the repeatedly verified data of [3], and this discrepancy at pressures of 1000 bar and a temperature of 1000°C reaches a magnitude of about 4%.

The tables of thermodynamic properties of nitrogen at high pressures and temperatures available at the present time, and obtained by a computational method [6, 7], have not been verified experimentally. The limits of applicability of the equations of state used, and also the validity of the assumptions made, can be determined only on the basis of experimental P-v-T data.

The present paper is devoted to the experimental investigation of the thermodynamic properties of nitrogen at pressures of up to 3-8 kbar and a temperature range of 400-1800°K.

Institute of High-Pressure Physics, Academy of Sciences of the USSR, Moscow. Translated from *Inzhenerno-Fizicheskii Zhurnal*, Vol. 33, No. 2, pp. 280-286, August, 1977. Original article submitted May 20, 1976.

This material is protected by copyright registered in the name of Plenum Publishing Corporation, 227 West 17th Street, New York, N.Y. 10011. No part of this publication may be reproduced, stored in a retrieval system, or transmitted, in any form or by any means, electronic, mechanical, photocopying, microfilming, recording or otherwise, without written permission of the publisher. A copy of this article is available from the publisher for \$7.50.

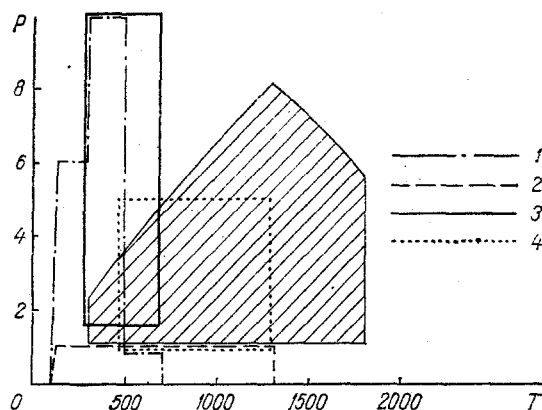

Fig. 1. Range of parameters of state of nitrogen, investigated experimentally by different authors: 1) data of [2]; 2) [3]; 3) [4]; 4) [5]; the hatched region shows the data from the present paper. P, kbar; T, °K.

The investigations were conducted on a specially developed high-pressure facility with internal heating of the gas [8]. A tungsten-rhenium alloy VR20 was used as the material for the heater. The addition of rhenium considerably increases the plasticity of the alloy, the temperature of the onset of recrystallization, and the stability of the material relative to the solubility of nitrogen in it.

The initial resistance of the heating element amounted to about 5 Ω . The ac power supply was effected through an RNO-40 transformer; the maximum voltage reached 250 V and the magnitude of the current in this case amounted to ~ 20 A.

The high-pressure and high-temperature equipment was part of the facility, including also a standard bottle of nitrogen compressed to ~ 150 atm, a pressure generator, and a calibrated reservoir of large volume (Fig. 2).

A thermocompressor — a high-pressure vessel with an internal volume of 264 cm³ — installed in a cryostat was used as the pressure generator. The pressure in the thermocompressor was generated by the cooling of gaseous nitrogen under a pressure of about 150 atm to the temperature of liquid nitrogen with subsequent heating in the closed volume. After five cycles of cooling and heating of the thermocompressor to a temperature of $\sim 100^\circ\text{C}$, an initial gas pressure in the system of about 2500 bar was obtained successfully with this equipment. A further increase of pressure occurred in the apparatus on heating up.

The calibrated reservoir with a volume of 41.95 liters served to determine the quantity of gas enclosed in the apparatus. For this purpose, after completion of the experiment, the gas was expanded into this reservoir, and after establishing thermal equilibrium, which was disturbed in consequence of the expansion process of the gas, its pressure and temperature were measured. The mass of gas was then determined by the equation of state of an ideal gas $Pv = RT$.

As a result of the operation of the high-pressure apparatus with internal heating, the presence of intense gas convection in it was confirmed. A detailed investigation of the characteristic features of this phenomenon was achieved for the first time in [1].

Gas convection in high-pressure equipment with internal heating disturbs the homogeneous nature of the temperature distribution inside the apparatus, which makes it difficult to carry out accurate thermophysical investigations. Thus, in the apparatus used the difference of temperatures measured by two thermocouples positioned at a distance of 7 mm from one another vertically reached 150° . Moreover, it was shown experimentally that the electric power necessary for generating a specified temperature inside the apparatus, because of the presence of gas convection, increases significantly with increase of pressure, in comparison with the case when convection is completely absent.

In order to eliminate gas convection inside the apparatus, some improvement was made to it. All the free space inside the apparatus was filled with a porous refractory material — aluminum nitride (porosity of 60%). As the measurement results of the temperature field

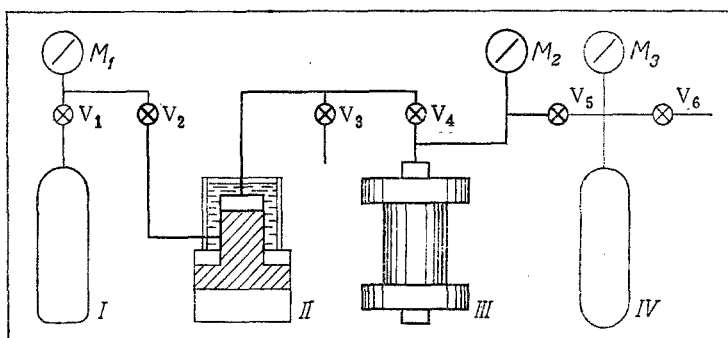

Fig. 2. Diagram of facility used for determining the density of nitrogen: I) standard bottle of compressed nitrogen; II) pressure generator; III) high-pressure equipment with internal heating; IV) calibrated reservoir.

inside the apparatus showed, filling of the entire free space of the thermal chamber with the porous material enabled gas convection in this volume to be eliminated completely and allowed a space with a constant temperature field and with adequate dimensions to be obtained. The temperature difference at a distance of 60 mm, measured by the two thermocouples, did not exceed the measurement error.

In order to determine the density of the nitrogen, a variant of the displacement method suitable for high-temperature measurements was developed. The principle of the displacement method, suggested in [4], consists of carrying out two successive measurements of a quantity of gas m_1 and m_2 filling a constant-volume piezometer at a known pressure P and temperature T ; in one of the experiments a monolithic insert with a known volume under normal conditions is arranged in the uniform temperature zone. The density of the gas at pressure P and temperature T is then determined by the formula

$$\rho(P, T) = \frac{\Delta m}{V_{\text{ins}}(P, T)}, \quad (1)$$

where $\Delta m = (m_1 - m_2)$ is the quantity of gas displaced from the piezometer by the insert under the conditions of the experiment and $V_{\text{ins}}(P, T)$ is the volume of the insert at pressure P and temperature T .

It is obvious that if the conditions for carrying out both measurements were identical, then all the corrections for the thermal and barometric deformation of the high-pressure vessel (and also possible errors due to the presence in the facility of ballast unheated spaces and a nonhomogeneous temperature distribution over the whole length of the thermal chamber) are mutually canceled out. It is necessary only to determine the volume of the insert under the conditions of the experiment. The volume of the insert under normal conditions can be determined with high accuracy, for example, by calibration in water, and the magnitude of the deformation of the insert by the action of the pressure and temperature can be calculated accurately.

In accordance with this procedure, the authors of [4] conducted two successive experiments at one and the same temperature, determining two relations between the quantity of gas and the pressure in the piezometer. This procedure requires the maintenance of an identical temperature with high accuracy while conducting both experiments, which proves to be extremely difficult at high temperatures when internal heating of the gas is used.

Therefore, in order to determine the quantity of gas displaced by the insert, two successive experiments were carried out (with and without insert) with constant amounts of gas in the piezometer. In both experiments, after filling the piezometer with a certain quantity of gas, the heating was switched on and the dependence of the gas pressure P in the piezometer on its temperature T was measured. As a result, two curves were obtained in the coordinates gas pressure versus temperature (Fig. 3).

It is obvious that these curves have a point of intersection, the coordinates of which determine the magnitudes of the pressure and temperature to which the value of the gas density — equal to the ratio of the mass of gas displaced by the insert $\Delta m = m_1 - m_2$ to the volume of the insert under the conditions of the experiment — corresponds.

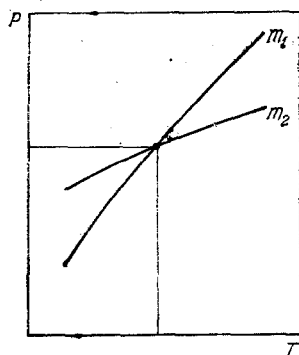

Fig. 3. Determination of the density of gases using the variant of the displacement method.

In view of the fact that while carrying out both experiments all the free space is filled with a porous material in order to suppress gas convection, formula (1) must be modified, and the density of the gas at pressure P and temperature T is determined from the expression

$$\rho(P, T) = \frac{\Delta m}{V_{\text{ins}}(P, T) - V_{\text{ipm}}(P, T)}, \quad (2)$$

where $V_{\text{ipm}}(P, T)$ is the volume of the porous material filling the site of the monolithic insert under the conditions of the experiment.

While conducting the experiment, 10-15 points corresponding to different values of the electric power fed in were determined for every initial nitrogen pressure in the apparatus. For each of these values of the power, a time delay was produced, necessary for establishing thermal equilibrium inside the apparatus. Concerning the establishment of this equilibrium, cessation of the temperature rise in the thermal chamber and the pressure in the system (and also cessation of the temperature rise measured by a thermocouple which was installed in the body of one of the obturators of the apparatus in the immediate vicinity of its inside end surface) was indicated. The delay time amounted to 0.5 to 1 h. Similar P - T measurements were carried out at a reduced temperature and each of the P - T points was obtained by averaging the two measurements. The experiment was assumed to be unsuccessful if the measurement results during heating up and cooling differed by an amount exceeding the error of the measuring instruments and also if, on attaining the starting temperature, the gas pressure in the system differed from the starting pressure by an amount exceeding the error of the manometer used, i.e., if leakage of the gas from the system had taken place during the experiment.

The pressure in the experiments was measured with a reference pointer-type manometer of grade 0.5 with a measurement limit of up to 1600 kg/cm³ and with a Manganin manometer calibrated by a piston manometer. The coil of the Manganin manometer was subjected to thermal and baric treatment in accordance with the well-known recommendations, and it was insulated from the gaseous medium with a steel bellows filled with aviation gasoline. The initial resistance of the coil amounted to 262 Ω . The measurement of the change of resistance of the coil under the experimental conditions was carried out by an R39 single-bridge circuit. The absolute error of the pressure measurement with both manometers did not exceed 20 bar.

The temperatures inside the thermal chamber were measured with a standard platinum-rhodium-platinum thermocouple No. 622, calibrated in the Moscow Metrological Service Center. The calibration error also of the secondary instrument used for measuring the thermal emf (R37-1 potentiometer) did not exceed 0.001 mV, which corresponds to 0.1° for this thermocouple.

When determining the temperature up to 1000°C, the known experimentally determined corrections for the dependence of the thermal emf of the thermocouple on the pressure were taken into account [9], and at higher temperatures these corrections were determined by an extrapolation method. Taking into account the indeterminacy in finding these corrections, and also the measurement results of the temperature field in the thermal chamber, it was assumed that the error of the temperature measurement in the experiments did not exceed 1°C.

The pressure in the calibrated reservoir, when determining the mass of gas contained in the apparatus, was measured by means of a 3-m U-shaped water manometer. The error in measuring the pressure, taking account of the correction for capillarity and saturated vapor pressure, was assumed equal to 1 mm water column.

TABLE 1. Smoothed Values of Density of Nitrogen (g/cm³)

P, kbar	T, °K															
	400	500	600	700	800	900	1000	1100	1200	1300	1400	1500	1600	1700	1800	
1.0	0.478	0.412	0.362	0.323	0.292	0.267	0.246	0.228	0.213	0.200	0.188	0.179	0.169	0.161	0.153	
1.5	0.567	0.504	0.451	0.409	0.375	0.346	0.321	0.300	0.282	0.266	0.252	0.239	0.228	0.218	0.209	
2.0	0.646	0.580	0.527	0.484	0.448	0.416	0.390	0.366	0.346	0.328	0.312	0.298	0.286	0.273	0.258	
2.5	0.704	0.638	0.586	0.543	0.506	0.474	0.446	0.421	0.399	0.380	0.363	0.348	0.334	0.321	0.309	
3.0	0.746	0.684	0.632	0.590	0.551	0.513	0.490	0.466	0.443	0.423	0.405	0.389	0.373	0.360	0.347	
3.5	—	0.721	0.671	0.628	0.591	0.558	0.530	0.504	0.481	0.460	0.442	0.424	0.409	0.395	0.382	
4.0	—	—	0.708	0.664	0.628	0.594	0.567	0.539	0.517	0.495	0.477	0.458	0.443	0.428	0.415	
4.5	—	—	—	0.697	0.660	0.628	0.598	0.573	0.551	0.528	0.508	0.490	0.474	0.459	0.446	
5.0	—	—	—	0.727	0.690	0.659	0.628	0.603	0.582	0.558	0.541	0.520	0.502	0.489	0.476	
5.5	—	—	—	—	0.717	0.685	0.657	0.630	0.609	0.585	0.565	0.547	0.530	0.514	0.500	
6.0	—	—	—	—	—	0.708	0.680	0.653	0.631	0.607	0.588	0.569	0.553	0.536	—	
6.5	—	—	—	—	—	—	0.700	0.675	0.651	0.629	0.609	0.590	0.573	—	—	
7.0	—	—	—	—	—	—	—	0.698	0.674	0.653	0.632	0.616	—	—	—	
7.5	—	—	—	—	—	—	—	—	0.701	0.679	0.658	—	—	—	—	
8.0	—	—	—	—	—	—	—	—	0.721	0.699	—	—	—	—	—	

The gas temperature in the calibrated reservoir was assumed to be equal to the temperature of the surrounding medium, which was measured with a mercury thermometer with an accuracy of 0.2°C.

The P-v-T data obtained as a result of the measurements were smoothed with respect to isotherms and isobars by means of the method of least squares for the purpose of comparing the fluctuations of the density values (within the limits of the measurement error) caused by random errors.

The smoothed values of the density of nitrogen are given in Table 1.

In certain regions of the range of parameters of state investigated, experimental P-v-T data of other authors are available. From a comparison analysis, it follows that the discrepancy between the results obtained and the experimental data of Tsiklis and Polyakov, Robertson and Babb, and also the data of Din and Wasserman, et al., which generalize the majority of the results of the other experimental papers, does not exceed the experimental error. The data of [9] are an exception; their deviation from the results obtained at a pressure below 3 kbar and temperatures above 500°C exceeds the experimental error, and this deviation increases with increase of temperature and at a pressure of 1 kbar and a temperature of 1000°C reaches a magnitude of 3.5%.

The discrepancy between the results obtained and the tabular data of [6, 7], obtained by a computational method from the equations of state, also does not exceed the experimental error.

NOTATION

P, pressure; v, specific volume; T, temperature; R, gas constant; ρ , density of gas; m, mass of gas; V_{ins} , volume of insert; V_{pm} , volume of porous material.

LITERATURE CITED

1. L. F. Vereshchagin and Ya. A. Kalashnikov, Zh. Tekh. Fiz., 25, No. 8 (1955).
2. F. Din, Thermodynamic Functions of Gases, Vol. 3, Butterworths, London (1961).
3. A. A. Wasserman, Ya. Z. Kazavchinskii, and V. A. Rabinovich, Thermophysical Properties of Air and Its Components [in Russian], Nauka, Moscow (1966).
4. D. S. Tsiklis and E. V. Polyakov, Dokl. Akad. Nauk SSSR, 176, No. 2 (1967).
5. P. Malbrunot and B. Vodar, Physica, 66, No. 2 (1969).
6. A. A. Antanovich, M. A. Plotnikov, and G. Ya. Savel'ev, Zh. Zh. Prikl. Mekh. Tekh. Fiz., No. 3 (1969).
7. N. A. Zykov and R. M. Sevast'yanov, in: Thermophysical Properties of Substances and Materials [in Russian], No. 8, Izd. Standartov, Moscow (1975), p. 222.
8. M. A. Plotnikov et al., Inzh.-Fiz. Zh., 20, No. 4 (1971).
9. P. Malbrunot and B. Vodar, High Temperatures—High Pressures, 3, No. 2 (1971).